



The **CheckMate®**

Check Jogger
for all your
Check 21 Act
processing
needs.

BLM Technologies, Inc.
14755 27th Avenue North
Plymouth, MN 55447
800.877.4280
www.blmtechnology.com

Syntron® *Strategic Solutions to Enhance Your Work Flow*

Could your strategic work flow benefit from a little streamlining? The **Syntron® CheckMate®** Jogger from FMC Technologies fits the bill.

- **Compact size**
 - Strategic placement close at hand
 - Weighs less than 10 pounds
 - Ideal for jogging small quantities of checks and envelopes
- **Simple operation**
 - Convenient stop/start bar
- **Advanced design**
 - Electromagnetic design allows continuous operation and eliminates overheating unlike motor-driven units
- **Proven Reliability**
 - Enjoy many years of reliable, maintenance-free service
- **Quality**
 - Units warranted to be free of defects in material and workmanship for one year from date of shipment
- **Safety**
 - Self-enclosed units, no exposed drive parts
 - Electromagnetic design eliminates sparking or burn-up associated with overheating
 - 115V / 60 Hz units are UL/CUL approved



Syntron® CheckMate® Paper Jogger Technical Data

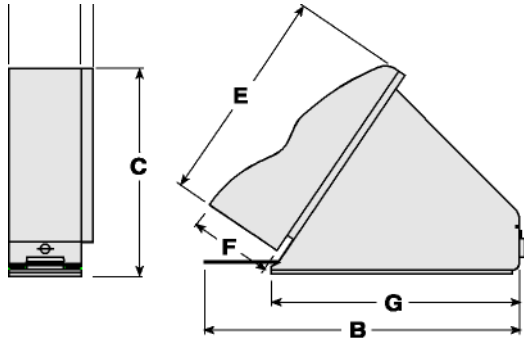

<i>Dimensions</i>							
	A	B	C	D	E	F	G
Inches	3 ³ / ₁₆	10 ⁵ / ₈	7	2 1/2	7 ⁵ / ₁₆	2 ³ / ₄	8 ³ / ₈
mm	81	270	178	64	186	70	213

Input Amps	115V, 60 Hz	4.0
Net Weight	10lbs	4.5 kg
Shipping Weight	12lbs	5.4 kg

For more than 60 years, FMC Technologies has manufactured Syntron® Electromagnetic Vibrating Paper Joggers to meet the varied needs of business and industry.

As the world's largest manufacturer of paper joggers, our commitment to our customers is unparalleled in the industry with the reliability and high-performance of our products.



BLM Technologies, Inc.
 14755 27th Avenue North
 Plymouth, MN 55447
 800.877.4280
www.blmtechnology.com

FMC Technologies

Material Handling Solutions
 FMC Technologies, Inc.
 57 Cooper Avenue, Homer City, PA
 15748

Caution: Syntron® CheckMate® Paper Joggers must be installed, operated and maintained in accordance with accompanying FMC Technologies Service Instructions. Failure to follow these instructions can result in serious personal injury, property damage or both. FMC Technologies Service Instructions accompany the shipment of equipment. If additional copies are required, they are available, free of charge form Material Handling Solutions, FMC Technologies, Inc., Homer City, PA 15748.